



CHANGING ROOM EQUIPMENT

Seat Stands • Cloakroom Benches • Hook Boards

CHANGING ROOM OVERVIEW

A complete range of locker stands, stand seats, benches, cloakroom units and hook boards designed and manufactured to meet the challenging, everyday demands of Schools, Gyms, Leisure facilities and the Emergency Services.

Products are made to order, so your order gets the attention to detail it deserves. Most frequently specified options are detailed, please call for alternative or bespoke requests on **02920 859600**

CHANGING ROOM BENEFITS

- Practical and functional
- Encourages good practice
- Optimises space
- Durable and strong
- Options for wet and dry areas
- Streamline aesthetics
- Coated in BioCote antimicrobial paint, increasing hygiene for users
- Easy to clean and virtually maintenance free

Our Standards and Awards. Inspiring Confidence.

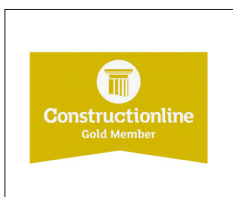

LOCKER STAND SEATS SPECIFICATION

- Steel frame durable powder paint coated
- Frame Colour: paint from the standard Garran range
- Seat slats colours:
Ash Slats -20mm thick clear varnish
SGL standard Garran range - 10mm thick
- Seat slats fixed through via the underside of the frame
- Suitable for locker depths: 300, 375 and 450mm
- Optional extra - aluminium frame, Silver texture finish

STAND SEATS

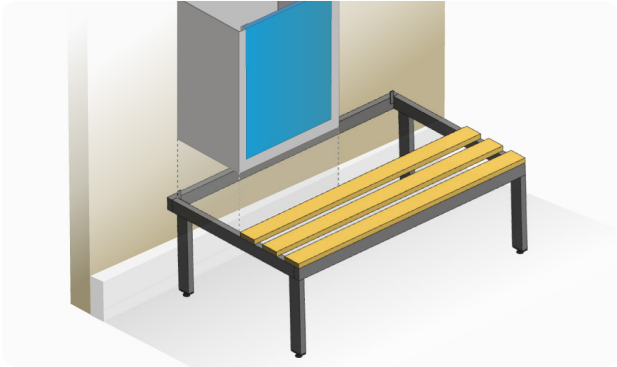

H 400mm
L 600, 750, 900, 1200, 1350, 1500, 1800mm
D 300 and 400mm

LOCKER STANDS SPECIFICATION

- Steel frame durable powder paint coated
- Frame Colour: paint from the standard Garran range
- Adjustable feet
- Welded construction
- Suitable for locker depths: 300, 375 and 450mm
- Optional extra - aluminium frame, Silver texture finish

LOCKER STANDS

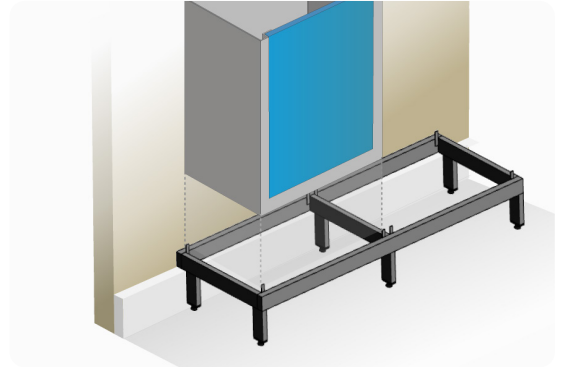

H 150mm
L 300, 450, 600, 750, 900, 1125, 1200, 1350, 1500, 1800mm
D 300, 375, 450mm

LOCKER STAND WITH MESH COMPARTMENTS

- Steel frame durable powder paint coated
- Frame Colour: paint from the standard Garran range
- Seat slats colours:
Ash Slats -20mm thick clear varnish
SGL standard Garran range - 10mm thick
- Seat slats fixed through via the underside of the frame
- Enclosed cage: back and side mesh

STAND SEATS

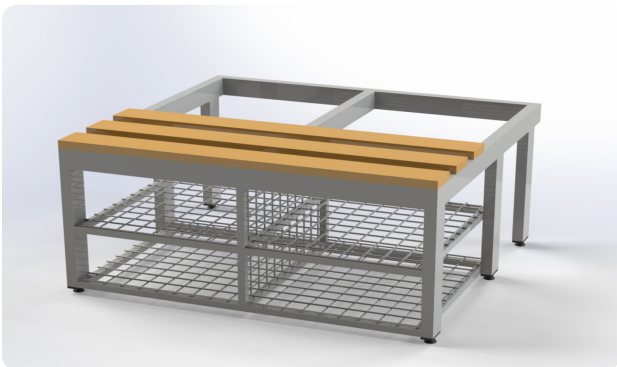

H 400mm
L 600, 900, 1200, 1500, 1800, 2000mm
D 300 and 400mm

KIT BAG LOCKER STAND

- Steel frame, steel door: durable powder paint coated
- Frame & Door Colour: paint from the standard Garran range
- SGL Top
- Single unit

*Visual shows 2x single units 450mm wide

STAND SEATS



H 400mm
D Max. 900mm

BENCH SEATS SPECIFICATION

- Steel frame durable powder paint coated
- Frame Colour: paint from the standard Garran range
- Seat slats colours:
Ash Slats -20mm thick clear varnish
SGL standard Garran range - 10mm thick
- Seat slats fixed through via the underside of the frame
- Free Standing
- Optional extra - floor fixing
- Optional extra - aluminium frame, Silver texture finish

BENCH SEATS



Optional extra perforated shoe shelf

H 400mm
L 600, 900, 1200, 1500mm
D 300 and 400mm

DOUBLE BENCH SEATS



Optional extra perforated shoe shelf

H 400mm
L 600, 900, 1200, 1500mm
D 650mm

SHOE SHELF BENCH SPECIFICATION

- Steel frame durable powder paint coated
- Frame Colour: paint from the standard Garran range
- Seat slats colours:
Ash Slats -20mm thick clear varnish
SGL standard Garran range - 10mm thick
- Seat slats fixed through via the underside of the frame
- Free Standing
- Optional extra - variable heights
- Optional extra - solid SGL seat
- Optional extra - floor fixing

SHOE SHELF BENCH

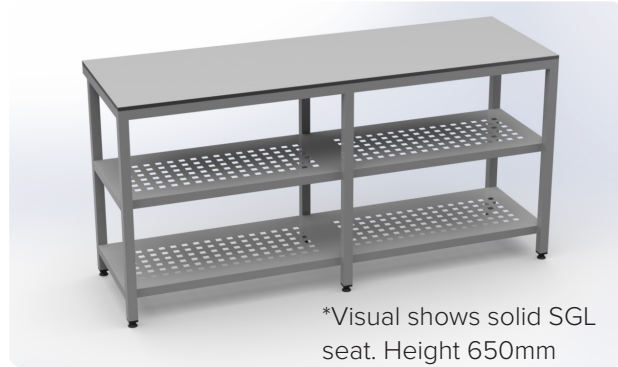

*Visual shows solid SGL seat. Height 650mm

H 650mm - variable heights available
L 600, 900, 1200, 1500mm
D 300 and 400mm

DOUBLE SHOE SHELF BENCH



*Visual shows solid SGL seat

H 650mm - variable heights available
L 600, 900, 1200, 1500mm
D 650mm

CLOAKROOM BENCHES

STANDARD SPECIFICATION

- Steel frame durable powder paint coated
- Frame Colour: paint from the standard Garran range
- Seat slats colours:
Ash Slats -20mm thick clear varnish
SGL standard Garran range - 10mm thick
- Seat slats fixed through via the underside of the frame
- Free Standing
- Hooks included

OPTIONAL EXTRAS

- Hook boards
- Backrest
- Wire mesh separations
- Mesh under seat storage
- Perforated metal
- Floor fixing
- Aluminium frame, Silver texture finish

SINGLE CLOAKROOM BENCH



H 1625mm
L 600, 900, 1200, 1500mm
D 350mm

DOUBLE CLOAKROOM

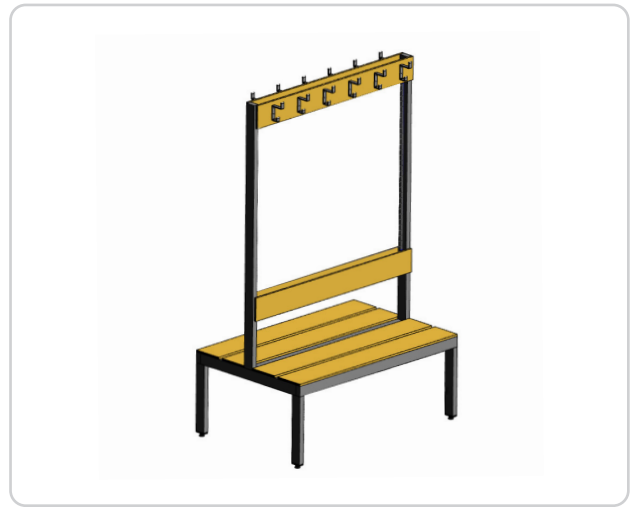

H 1625mm
L 600, 900, 1200mm
D 650mm

**DOUBLE HOOKBOARD
SINGLE CLOAKROOM BENCH**



*Visual shows
Inset legs

H 1625mm
L 600, 900, 1200, 1500mm
D 350mm

**DRYING RACK SHELF
SINGLE CLOAKROOM BENCH**



*Visual shows
Inset legs

H 1625mm
L 600, 900, 1200mm
D 350mm

CLOAKROOM BENCHES

DOUBLE HOOKBOARD
DOUBLE CLOAKROOM BENCH

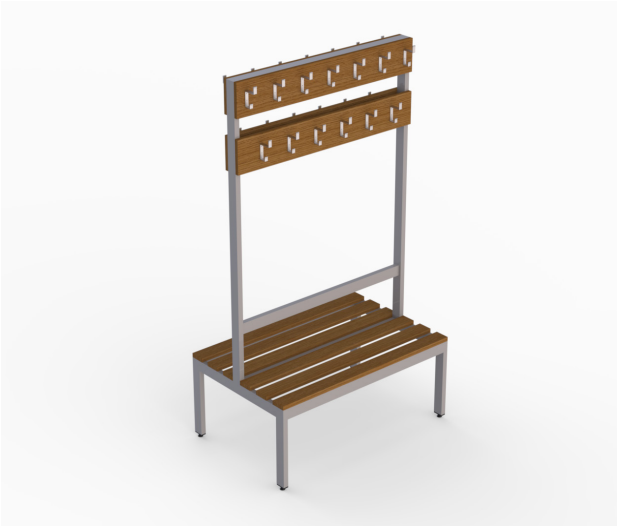

H 1625mm
L 600, 900, 1200mm
D 650mm

DRYING RACK SHELF
DOUBLE CLOAKROOM BENCH



H 1625mm
L 600, 900, 1200mm
D 650mm

HANG RAIL SPECIFICATION

- Steel frame durable powder paint coated
- Colours: SGL standard Garran range
- Hangers optional
- Variations available on request

HOOK BOARDS SPECIFICATION

- Board colours:
Ash - 18mm thick clear varnish
SGL standard Garran range - 10mm thick
- Additional Hooks optional extra, centres can be adjusted to suit

HANG RAIL



H 140mm
L per metre
D 450mm

HOOK BOARD



ASH
H 110mm
L 600 (2 hooks), 900 (3 hooks), 1200 (4 hooks) up to 2000mm
(300mm centers)
D 18mm

SGL
H 140mm
L 600 (2 hooks), 900 (3 hooks), 1200 (4 hooks) up to 1800mm
(300mm centers)
D 10mm

Bespoke options available email
projects@garran-workspaces.co.uk
for your FREE quote

PROJECT : BUZZ GYM

Buzz Gyms' 18,000 square foot fitness club on the rooftop of the Westgate Shopping Centre includes two immersive studio spaces, top of the range equipment, live djs, a huge free weight training zone complete with Eleiko performance equipment and a fantastic cross training area.

To help complete this exciting £1.5 million state of the art gym, Garran lockers were approached to design, manufacture and install bespoke storage lockers for both the male and female changing room areas that match the high quality seen throughout the

Having worked closely with gyms, sports facilities and leisure centres for several years Garran were chosen and set out to design and manufacture a selection of lockers and seating for the project.

With the requirements set, a selection of our Premier lockers were the product of choice, with their robust Solid grade laminate doors and premium quality finish along with a selection of locker stands and stand seating to complete an installation that met all the requirements.



PROJECT : THE GRANGE UNIVERSITY HOSPITAL

We are proud of our team at GARRAN for helping The Grange University Hospital open four months ahead of schedule, supporting Aneurin Bevan University Health Board in responding to winter pressures and the coronavirus pandemic.

Our recent installation and well planned phased install of 1000No. Multi-purpose steel lockers and benches look amazing in this brand new building!



Bespoke options available email
projects@garran-workspaces.co.uk
for your FREE quote

STEEL PAINT

FRAME FINISHES

Paints unless detailed below are MATT finish - 30% Gloss.
Feature BioCote antimicrobial technology which reduces the presence of microbes by up to 99.99%. BioCote is permanent and complements existing cleaning practices.



STANDARD COLOURS



BLACK
GAK-MN204E



IRIS
GAK-EJ201E



WHITE RAL 9003
GAK-MA585E



IRISH
GAK-EK280E

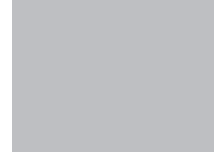

LIGHT GREY
GAK-EL206E



CORNFLOWER
GAK-EJ203E



POPPY
GAK-EG290E



FLINT
GAK-EL209E

PREMIUM COLOURS - OPTIONAL EXTRA - MOQ 10* Units



NEW
GRAPHITE - TEXTURE
GAK-MW333E



GLACIER
GAK-EK216E



HEATHER
GAK-EH227E



PEARL
GAK-ED204E



CHOCOLATE
GAK-EM210E



PINE
GAK-EF200E



NEW
CLEAR LACQUER
FINISH



REEF
GAK-EK221E



DAFFODIL
GAK-EE250E



SAND
GAK-EE220E



NEW
JAFFA
RAL 2003
*MOQ 20

Clear lacquer, BioCote antimicrobial coating not included.

SGL - SLAT FINISHES

Solid Grade Laminate - 10mm, double sided decorative board designed to meet the most demanding specifications for interior applications.

Ideal for areas with high levels of humidity, and applications requiring superior hygiene and maintenance levels.

FAST TRACK - STOCKED SGL



DUST



DARK GREY



ELECTRIC BLUE



RED DYNASTY

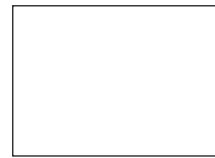

PEARLY WHITE



LIME



LIME YELLOW



REFRESH OAK

SUSTAINABLE DESIGN

Ongoing investment in facilities, equipment and systems means we continuously improve business efficiency, whilst significantly enhancing the working environment for our people.

